

PRODUCT FEATURES

- IGBT³ CHIP(Trench+Field Stop technology)
- Low saturation voltage and positive temperature coefficient
- Fast switching and short tail current
- Free wheeling diodes with fast and soft reverse recovery
- Temperature sense included

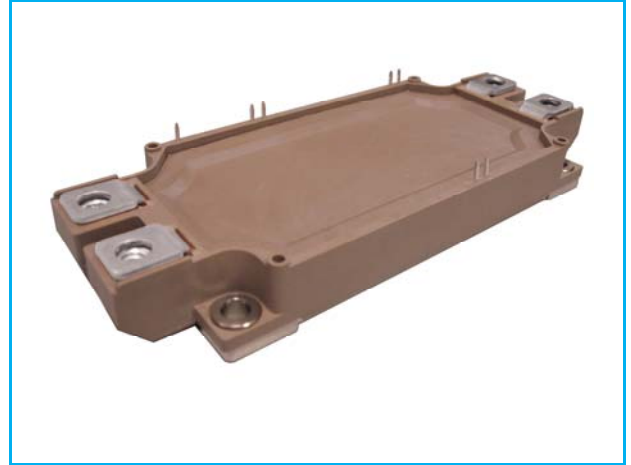

APPLICATIONS

- AC motor control
- Motion/servo control
- Inverter and power supplies
- Photovoltaic/Fuel cell

IGBT-inverter

ABSOLUTE MAXIMUM RATINGS($T_C=25^{\circ}\text{C}$ unless otherwise specified)

| Symbol | Parameter/Test Conditions | Values | Unit | |
|-----------|-----------------------------------|--|----------|---|
| V_{CES} | Collector Emitter Voltage | $T_J=25^{\circ}\text{C}$ | 1200 | V |
| V_{GES} | Gate Emitter Voltage | | ± 20 | |
| I_C | DC Collector Current | $T_C=25^{\circ}\text{C}, T_{Jmax}=150^{\circ}\text{C}$ | 450 | A |
| | | $T_C=80^{\circ}\text{C}, T_{Jmax}=150^{\circ}\text{C}$ | 300 | |
| I_{CM} | Repetitive Peak Collector Current | $t_p=1\text{ms}$ | 600 | |
| P_{tot} | Power Dissipation Per IGBT | $T_C=25^{\circ}\text{C}, T_{Jmax}=150^{\circ}\text{C}$ | 1400 | W |

Diode-inverter

ABSOLUTE MAXIMUM RATINGS ($T_C=25^{\circ}\text{C}$ unless otherwise specified)

| Symbol | Parameter/Test Conditions | Values | Unit | |
|-------------|---------------------------------|---|------|-------------------|
| V_{RRM} | Repetitive Reverse Voltage | $T_J=25^{\circ}\text{C}$ | 1200 | V |
| $I_{F(AV)}$ | Average Forward Current | | 300 | A |
| I_{FRM} | Repetitive Peak Forward Current | $t_p=1\text{ms}$ | 600 | |
| I^2t | | $T_J=125^{\circ}\text{C}, t=10\text{ms}, V_R=0\text{V}$ | 17.5 | KA ² S |

MacMic Science & Technology Co., Ltd.

Add: #18, Hua Shan Zhong Lu, New District, Changzhou City, Jiangsu Province, P. R. of China

Tel.: +86-519-85163708 Fax: +86-519-85162291 Post Code: 213022 Website: www.macmicst.com

MMG300WB120B6TN

IGBT-inverter

ELECTRICAL CHARACTERISTICS ($T_C=25^\circ\text{C}$ unless otherwise specified)

| Symbol | Parameter/Test Conditions | | Min. | Typ. | Max. | Unit |
|---------------|--|---|-------------------------|------|------|---------------|
| $V_{GE(th)}$ | Gate Emitter Threshold Voltage | $V_{CE}=V_{GE}, I_C=12\text{mA}$ | 5.0 | 5.8 | 6.5 | V |
| $V_{CE(sat)}$ | Collector Emitter Saturation Voltage | $I_C=300\text{A}, V_{GE}=15\text{V}, T_J=25^\circ\text{C}$ | | 1.7 | 2.15 | |
| | | $I_C=300\text{A}, V_{GE}=15\text{V}, T_J=125^\circ\text{C}$ | | 2.0 | | |
| I_{CES} | Collector Leakage Current | $V_{CE}=1200\text{V}, V_{GE}=0\text{V}, T_J=25^\circ\text{C}$ | | | 1 | mA |
| | | $V_{CE}=1200\text{V}, V_{GE}=0\text{V}, T_J=125^\circ\text{C}$ | | | 5 | mA |
| I_{GES} | Gate Leakage Current | $V_{CE}=0\text{V}, V_{GE}=\pm 15\text{V}, T_J=25^\circ\text{C}$ | -400 | | 400 | nA |
| R_{gint} | Integrated Gate Resistor | | | 2.5 | | Ω |
| Q_g | Gate Charge | $V_{CE}=600\text{V}, I_C=300\text{A}, V_{GE}=\pm 15\text{V}$ | | 2.7 | | μC |
| C_{ies} | Input Capacitance | $V_{CE}=25\text{V}, V_{GE}=0\text{V}, f=1\text{MHz}$ | | 21 | | nF |
| C_{res} | Reverse Transfer Capacitance | | | 1 | | nF |
| $t_{d(on)}$ | Turn on Delay Time | $V_{CC}=600\text{V}, I_C=300\text{A}$ $R_G=2.4\Omega,$ $V_{GE}=\pm 15\text{V},$ Inductive Load | $T_J=25^\circ\text{C}$ | | 160 | ns |
| | | | $T_J=125^\circ\text{C}$ | | 170 | ns |
| t_r | Rise Time | Inductive Load | $T_J=25^\circ\text{C}$ | | 45 | ns |
| | | | $T_J=125^\circ\text{C}$ | | 50 | ns |
| $t_{d(off)}$ | Turn off Delay Time | $V_{CC}=600\text{V}, I_C=300\text{A}$ $R_G=2.4\Omega,$ $V_{GE}=\pm 15\text{V},$ Inductive Load | $T_J=25^\circ\text{C}$ | | 460 | ns |
| | | | $T_J=125^\circ\text{C}$ | | 530 | ns |
| t_f | Fall Time | Inductive Load | $T_J=25^\circ\text{C}$ | | 100 | ns |
| | | | $T_J=125^\circ\text{C}$ | | 150 | ns |
| E_{on} | Turn on Energy | $V_{CC}=600\text{V}, I_C=300\text{A}$ $R_G=2.4\Omega,$ $V_{GE}=\pm 15\text{V},$ Inductive Load | $T_J=25^\circ\text{C}$ | | 13 | mJ |
| | | | $T_J=125^\circ\text{C}$ | | 20 | mJ |
| E_{off} | Turn off Energy | Inductive Load | $T_J=25^\circ\text{C}$ | | 25 | mJ |
| | | | $T_J=125^\circ\text{C}$ | | 37 | mJ |
| I_{SC} | Short Circuit Current | $t_{psc} \leq 10\mu\text{s}, V_{GE}=15\text{V}$ $T_J=125^\circ\text{C}, V_{CC}=900\text{V}$ | | 1200 | | A |
| R_{thJC} | Junction to Case Thermal Resistance (Per IGBT) | | | | 0.09 | K/W |

Diode-inverter

ELECTRICAL CHARACTERISTICS ($T_C=25^\circ\text{C}$ unless otherwise specified)

| Symbol | Parameter/Test Conditions | | Min. | Typ. | Max. | Unit |
|-------------|---|--|------|------|------|------|
| V_F | Forward Voltage | $I_F=300\text{A}, V_{GE}=0\text{V}, T_J=25^\circ\text{C}$ | | 1.65 | 2.15 | V |
| | | $I_F=300\text{A}, V_{GE}=0\text{V}, T_J=125^\circ\text{C}$ | | 1.65 | | |
| t_{rr} | Reverse Recovery Time | $I_F=300\text{A}, V_R=600\text{V}$ | | 225 | | ns |
| I_{RRM} | Max. Reverse Recovery Current | $di_f/dt=-4800\text{A}/\mu\text{s}$ $T_J=125^\circ\text{C}$ | | 255 | | A |
| E_{rec} | Reverse Recovery Energy | | | 24 | | mJ |
| R_{thJCD} | Junction to Case Thermal Resistance (Per Diode) | | | | 0.16 | K/W |

MMG300WB120B6TN

NTC CHARACTERISTICS ($T_C=25^\circ\text{C}$ unless otherwise specified)

| Symbol | Parameter/Test Conditions | Min. | Typ. | Max. | Unit |
|-------------|---|------|------|------|------------------|
| R_{25} | Resistance $T_C=25^\circ\text{C}$ | | 5 | | $\text{K}\Omega$ |
| $B_{25/50}$ | $R_2 = R_{25} \exp [B_{25/50}(1/T_2 - 1/(298.15 \text{ K}))]$ | | 3375 | | K |

MODULE CHARACTERISTICS ($T_C=25^\circ\text{C}$ unless otherwise specified)

| Symbol | Parameter/Test Conditions | Values | Unit | |
|------------|-----------------------------|----------------------------|------------------|----|
| T_{Jmax} | Max. Junction Temperature | 150 | $^\circ\text{C}$ | |
| T_{Jop} | Operating Temperature | -40~125 | | |
| T_{stg} | Storage Temperature | -40~125 | | |
| V_{isol} | Isolation Breakdown Voltage | AC, 50Hz(R.M.S), t=1minute | 3000 | V |
| CTI | Comparative Tracking Index | | > 225 | |
| Torque | to heatsink | Recommended (M5) | 2.5~5 | Nm |
| | to terminal | Recommended (M6) | 3~5 | Nm |
| Weight | | | 350 | g |

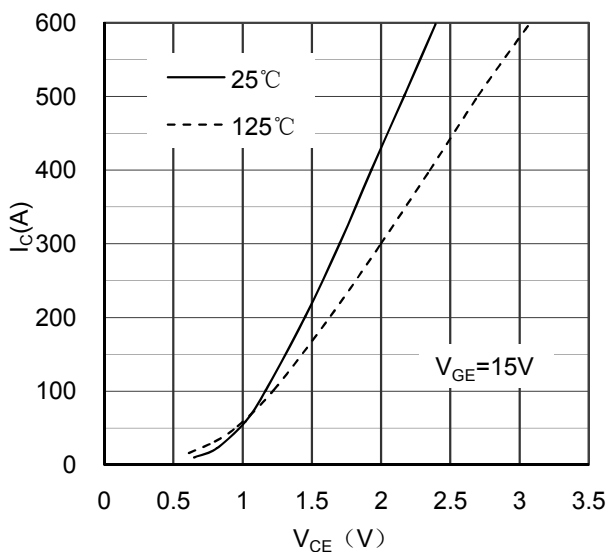

Figure 1. Typical Output Characteristics IGBT-inverter

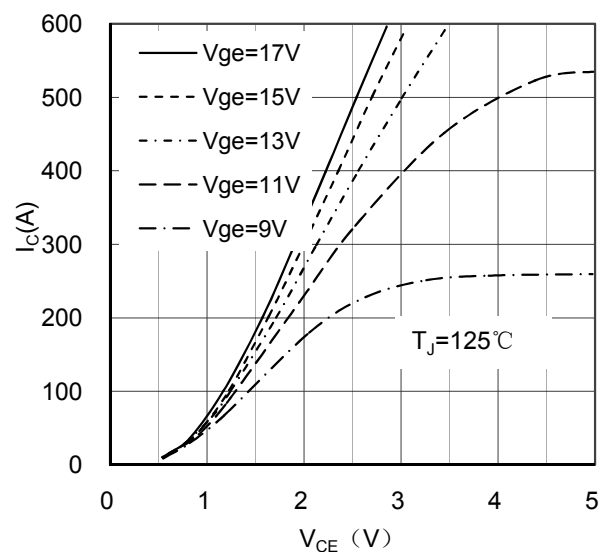

Figure 2. Typical Output Characteristics IGBT-inverter

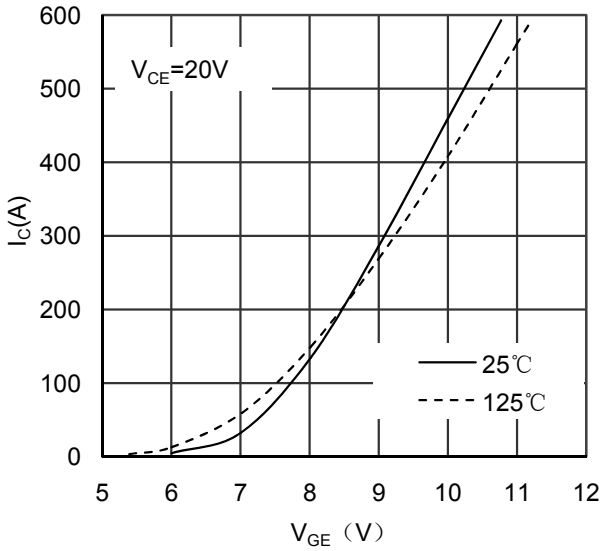

Figure 3. Typical Transfer characteristics IGBT-inverter

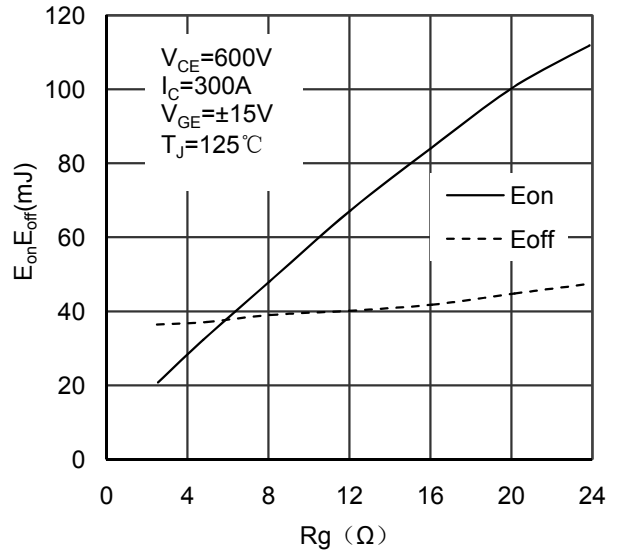

Figure 4. Switching Energy vs Gate Resistor IGBT-inverter

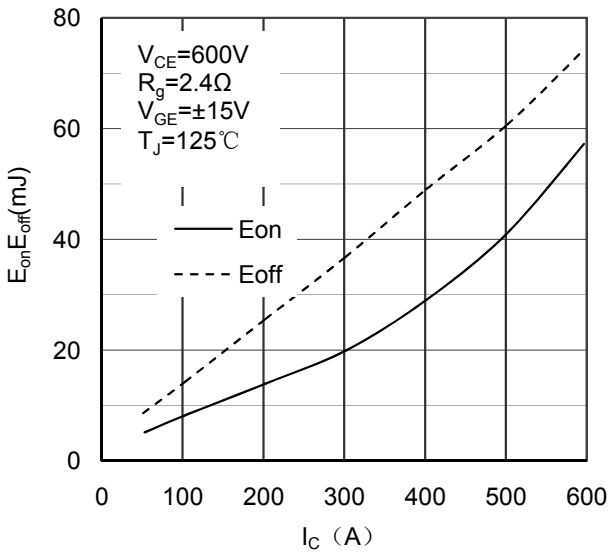

Figure 5. Switching Energy vs Collector Current IGBT-inverter

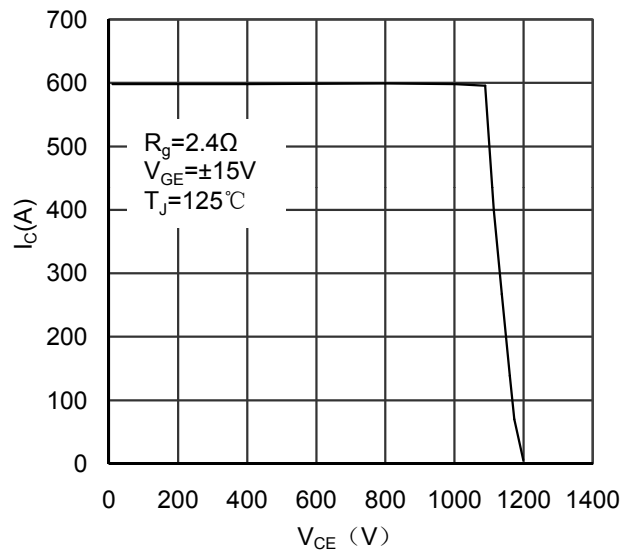

Figure 6. Reverse Biased Safe Operating Area IGBT-inverter

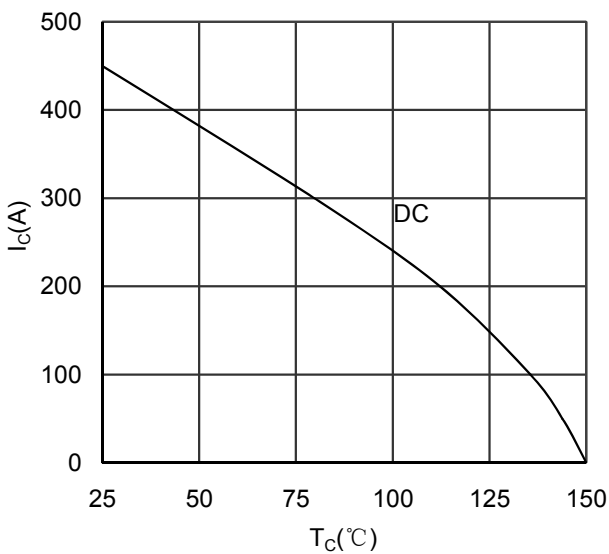

Figure 7. Collector Current vs Case temperature IGBT-inverter

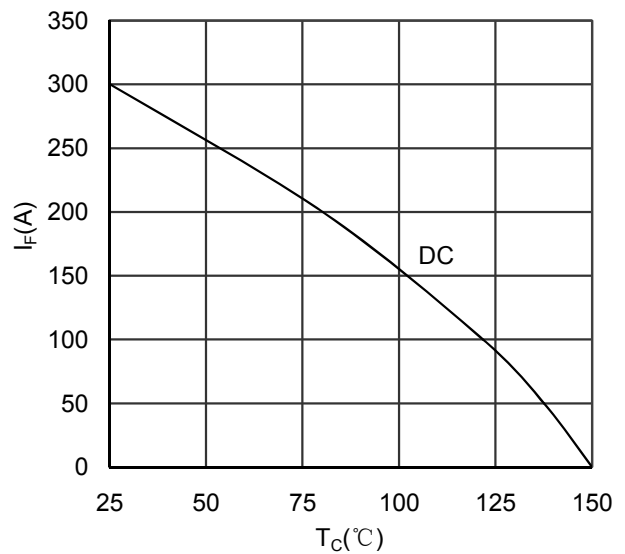

Figure 8. Forward current vs Case temperature Diode-inverter

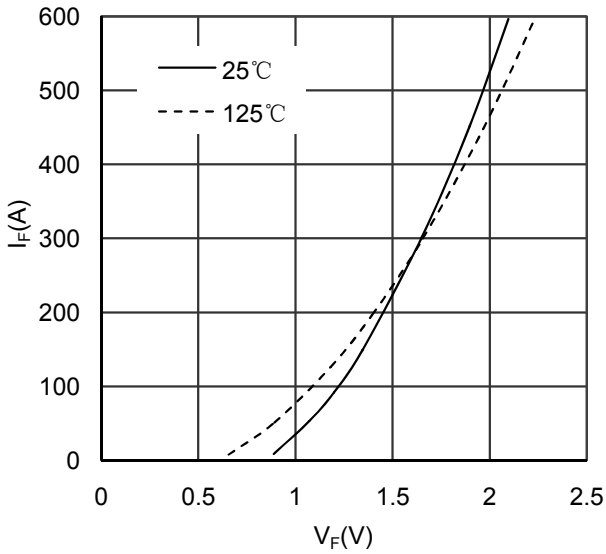

Figure 9. Diode Forward Characteristics Diode -inverter

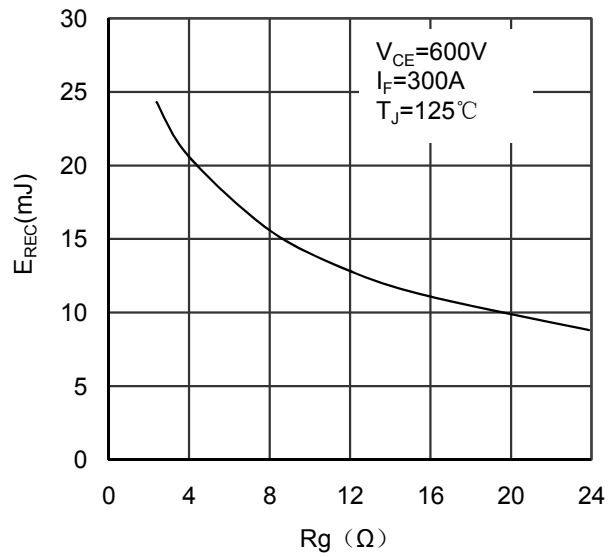

Figure 10. Switching Energy vs Gate Resistor Diode - inverter

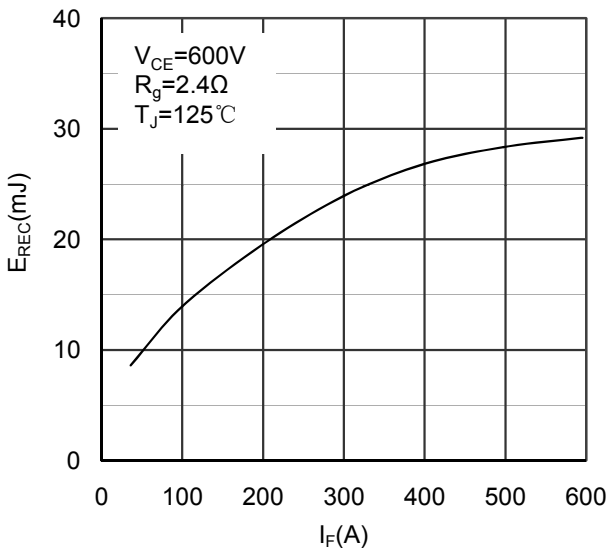

Figure 11. Switching Energy vs Forward Current Diode-inverter

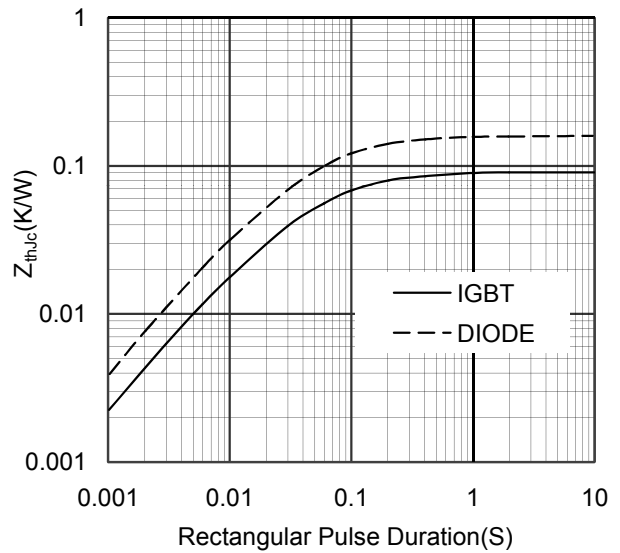

Figure 12. Transient Thermal Impedance of Diode and IGBT-inverter

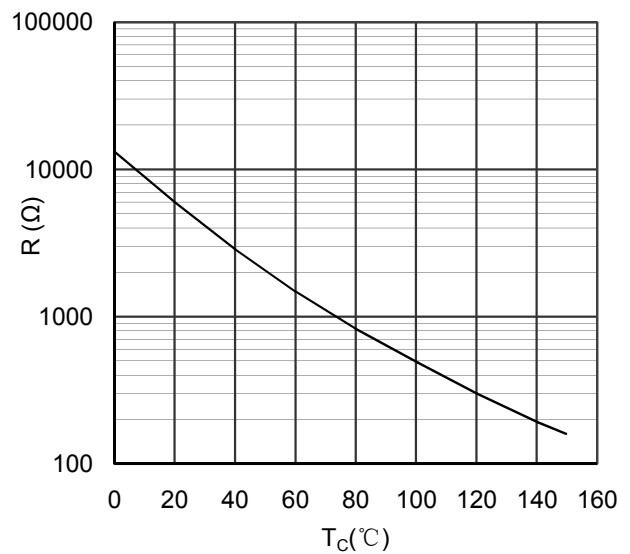

Figure 13. NTC Characteristics

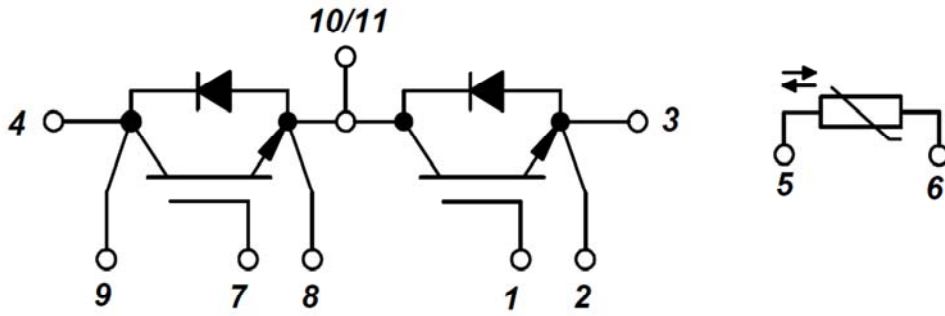

Figure 14. Circuit Diagram

